



Jin Global
Jinghui Hardware Co., Ltd.

PRODUCT CATALOGUE 2026

Premium Hardware Behind Everyday Fashion



jinglobal.co



About us

Our Story

Our story begins in Guangzhou, China, where **Jinghui Hardware** has been crafting high-quality hardware for over 20 years. What started as a family-owned workshop has grown into a foundation of reliability, skill, and dedication.

In 2025, we took a bold step toward the global stage. We established **Jin Global** in **Rotterdam, the Netherlands**, to better serve clients worldwide. This allows us to bridge our manufacturing excellence with global business needs, providing seamless support and solutions across borders.

What We Offer

Metal hardware remains at the center of our work. **Charms & Straps for Bags & Phones** are natural extensions of our core capabilities.

Leveraging our reliable supply chain and international experience, we deliver solutions that unlock your products' full potential.

Design | Custom Project | OEM | ODM

Raw Materials

ZAMAK (ZINC ALLOY) IS ECO-FRIENDLY & 100% RECYCLABLE.

Surface Finishes

MULTIPLE OPTIONS TO PREVENT CORROSION & IMPROVE AESTHETICS

Quality Control

TESTS TO ENSURE COMPLIANCE WITH REGULATIONS SUCH AS REACH AND ROHS

Staff Care

WE ARE COMMITTED TO A SAFE AND FAIR WORKPLACE, WITH ONGOING IMPROVEMENTS IN EMPLOYEE WELL-BEING.

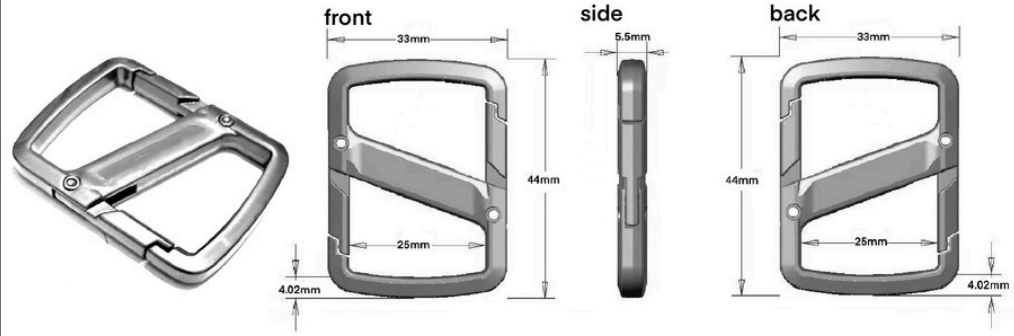
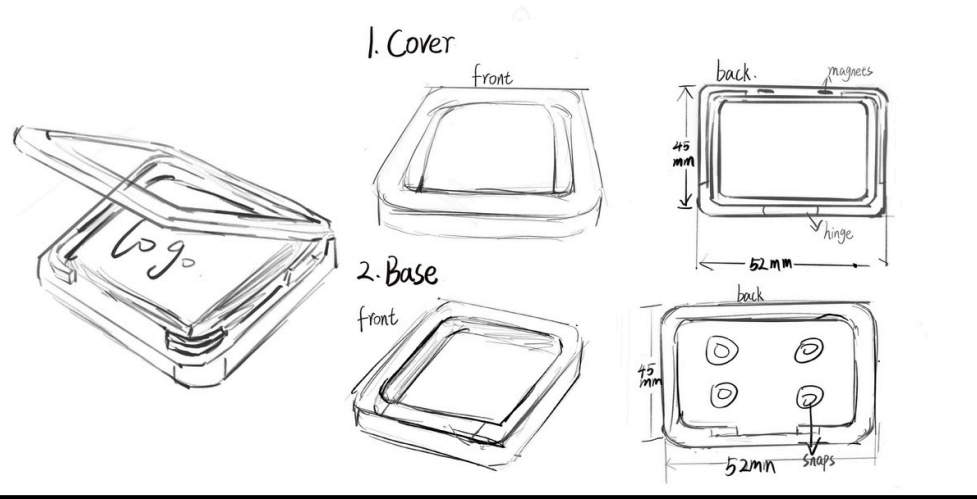

Research & Development

✓ Reach Compliance



Our R&D covers two parallel directions:



Upgrading existing hardware & Developing new solutions through in-house and collaborative design efforts.

Both are grounded in manufacturing feasibility and long-term production stability.

Improving What Exists.
Creating What Comes Next

From Experience to Innovation

Building on decades of manufacturing experience, our research focuses on understanding key variables that affect quality, appearance, and performance.

We refine processes, raise quality standards, and validate improvements before scale.



At the same time, we actively participate in product development – translating validated insights and market needs into manufacturable, reliable metal components for bags, pet products, apparel, etc.





Sustainability & Responsibility

At Jin Global, sustainability is not a separate initiative or a marketing statement.

It is built into materials, processes, and decisions. It is a result of how we design, manufacture, and control our hardware products over time.

Materials

Our core products are based on Zamak zinc alloy, selected for its balance of strength, precision, and recyclability.

- ✓ 95% less energy to recycle than primary production.
- ✓ Low-temperature casting (385°C) = Massive carbon reduction in Scope 3.
- ✓ 100% infinitely recyclable.

Environment

Significant focus has been placed on minimizing environmental impact by implementing a water purification system and high-efficiency suction systems. These upgrades ensure low emissions while maintaining a safe, healthy environment for our workforce.

People

Our production team is built on long-term technical experience rather than short-term labor rotation. Most of our employees have been with us since the beginning of our journey. We give great importance to safety and health in the workplace.

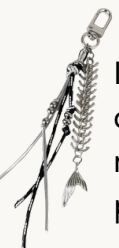

BUCKLES



2304

Material: Zamak 3/5 Zinc Alloy
Surface Finish: Rack Plating, Nickel

2723
Material: Zamak 3/5 Zinc Alloy
Surface Finish: Rack Plating, Satin Nickel



2500

Material: Zamak 3/5 Zinc Alloy
Surface Finish: E-Coating, Black

- Sizes:**
- 10mm (3/8")
 - 13mm (1/2")
 - 20mm (3/4")
 - 25mm (1")
 - 32mm (1¼")
 - 38mm (1½")
 - 50mm (2")

2503
Material: Zamak 3/5
Surface Finish: Rack Plating, Gold



BUCKLES



1610

Material: Zamak 3/5 Zinc Alloy

Surface Finish: Rack Plating, Gunmetal



2640

Material: Zamak 3/5 Zinc Alloy

Surface Finish: Rack Plating, Satin Nickel



2721

Material: Zamak 3/5 Zinc Alloy

Surface Finish: E-Coating, Black

- Sizes:**
- 10mm (3/8")
 - 13mm (1/2")
 - 20mm (3/4")
 - 25mm (1")
 - 32mm (1¼")
 - 38mm (1½")
 - 50mm (2")

2761
 Material: Zamak 3/5 Zinc Alloy
 Surface Finish: Rack Plating,
 Gunmetal



BUCKLES



26.7mm



8.3mm

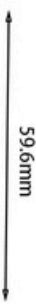

59.6mm

A1900

Material: Zamak 3/5 Zinc Alloy + PVC

Surface Finish: Rack Plating, Satin Nickel, Matt



25.7mm



7.6mm



44mm

A2716

Material: Zamak 3/5 Zinc Alloy
Surface Finish: E-Coating, Black



20mm



9mm



49mm

XHJ2020

Material: Zamak 3/5 Zinc Alloy + PVC

Surface Finish: Rack Plating, Gunmetal

Sizes:

- 10mm (3/8")
- 13mm (1/2")
- 20mm (3/4")
- 25mm (1")
- 32mm (1¼")
- 38mm (1½")
- 50mm (2")

XHJ1017

Material: Zamak 3/5 + PVC
Surface Finish: Rack Plating,
Gunmetal



38mm



12.7mm



70.6mm

RINGS

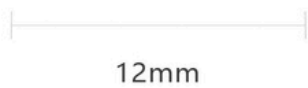

12mm



2.8 mm



13.5 mm

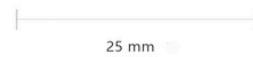

25 mm



2.5 mm

A937

Material: Zamak 3/5 Zinc Alloy
Surface Finish: Rack Plating, Gold

1539

Rack Plating, Gold



25mm



4.5 mm

26 mm

A193

Rack Plating, Gunmetal



25mm



3.0 mm

20 mm

5014

Material: Zamak 3/5 Zinc Alloy
Surface Finish: Rack Plating, Chrome



13.4 mm



2.8 mm

15mm

2192

Rack Plating, Nickel

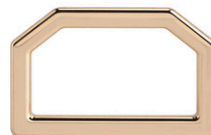

32mm



3.3 mm

25mm

2349

Rack Plating, Gold



38 mm



3.3 mm

18mm

1085

Rack Plating, Chrome

Sizes:

10mm (3/8"), 13mm (1/2"), 20mm (3/4"), 25mm (1"), 32mm (1¼"), 38mm (1½"), 50mm (2")

RINGS



2030

Material: Zamak 3/5 Zinc Alloy
Surface Finish: Rack Plating, Nickel

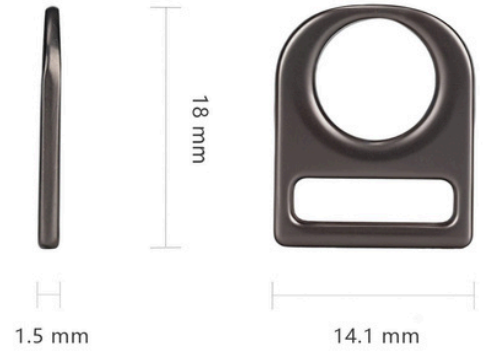

2143

Rack Plating, Gunmetal, Matt

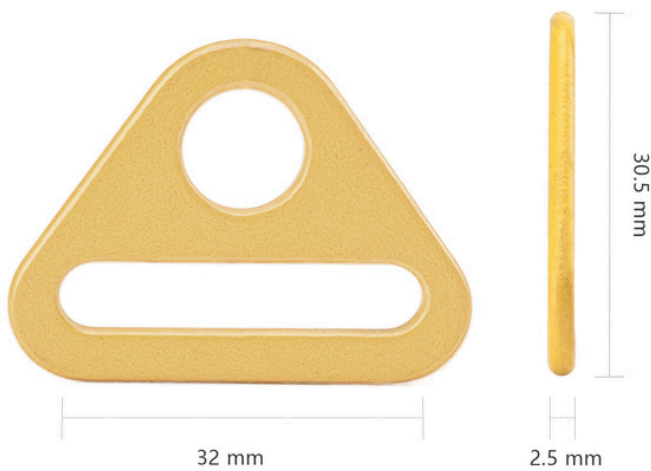

114

Material: Zamak 3/5 Zinc Alloy
Surface Finish: Baked Enamel, Yellow

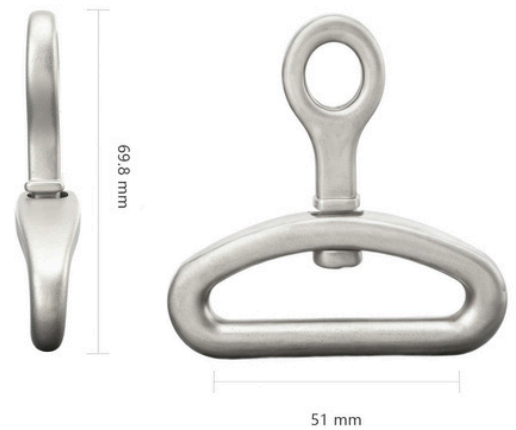

2147+2149

Barrel Plating, Nickel, Matt



2300

E-Coating, Black



2255

Rack Plating, Nickel



2882

Rack Plating, Gunmetal, Matt

Sizes:

10mm (3/8"), 13mm (1/2"), 20mm (3/4"), 25mm (1"), 32mm (1¼"), 38mm (1½"), 50mm (2")

SLIDERS

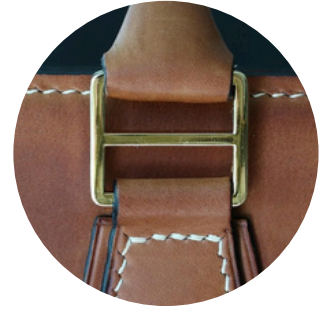

A1834, E-Coating, Matt

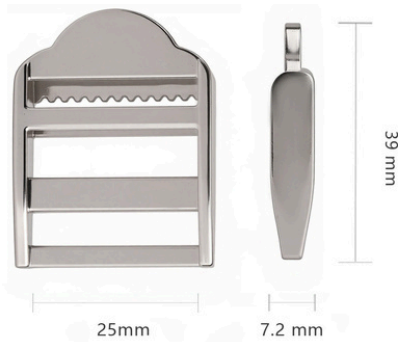

2440, Rack Plating, Nickel

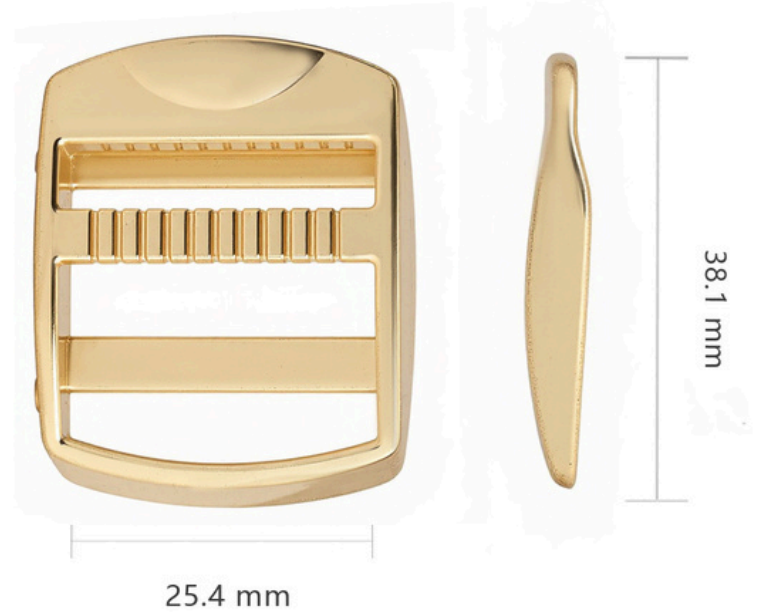

2778

Material: Zamak 3/5 Zinc Alloy
Surface Finish: Rack Plating, Gold, Matt



A1836

Material: Zamak 3/5 Zinc Alloy
Surface Finish: E-Coating, Black



A1781, Rack Plating, Satin Chrome

2316

Rack Plating, Nickel

Sizes:

10mm (3/8"), 13mm (1/2"), 20mm (3/4"), 25mm (1"), 32mm (1¼"), 38mm (1½"), 50mm (2")

SLIDERS

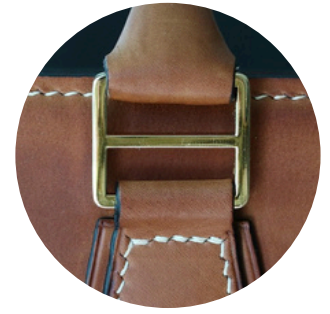

2818

Material: Zamak 3/5 Zinc Alloy
Surface Finish: E-Coating, Black, Matt



2791

E-Coating, Black, Matt

- Sizes:**
- 10mm (3/8")
 - 13mm (1/2")
 - 20mm (3/4")
 - 25mm (1")
 - 32mm (1¼")
 - 38mm (1½")
 - 50mm (2")

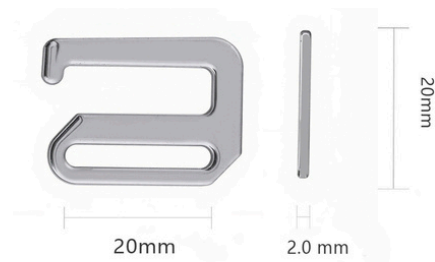

1450, Rack Plating, Nickel



1655, E-Coating, Black, Matt

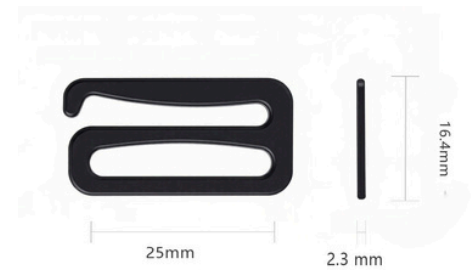

2522, E-Coating, Black, Matt

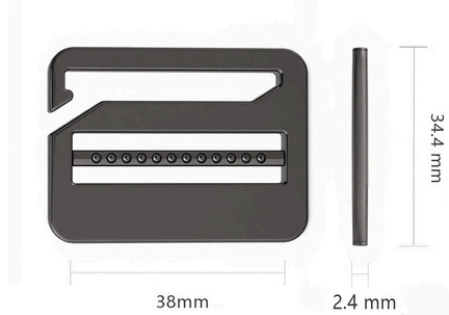

2424, Rack Plating, Gunmetal, Matt

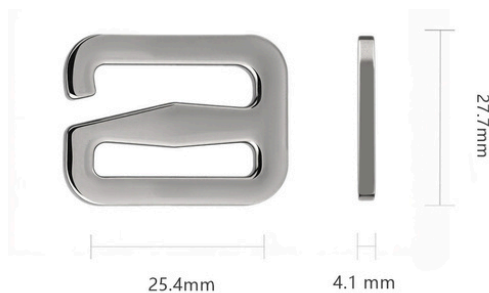

2383, Rack Plating, Chrome



A2513

Material: Zamak 3/5 Zinc Alloy
Surface Finish: E-Coating, Black, Matt

SLIDERS

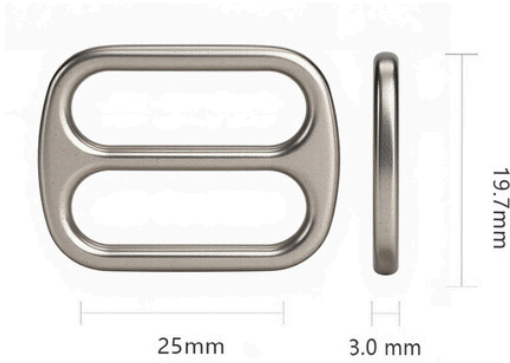
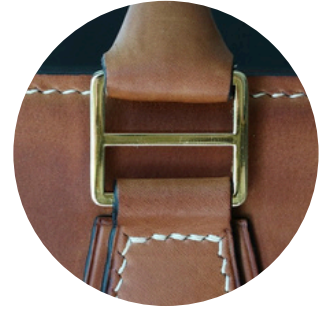

1522
Barrel Plating, Nickel, Matt

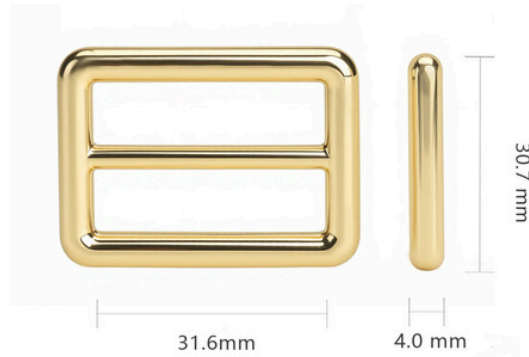

2769
Rack Plating, Gold

- Sizes:**
- 10mm (3/8")
 - 13mm (1/2")
 - 20mm (3/4")
 - 25mm (1")
 - 32mm (1¼")
 - 38mm (1½")
 - 50mm (2")

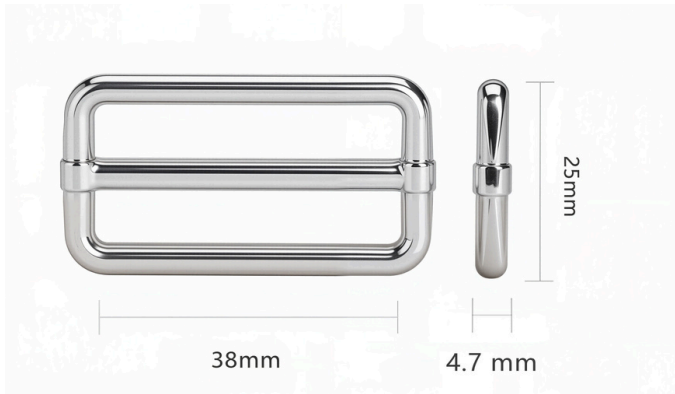

929
Rack Plating, Nickel

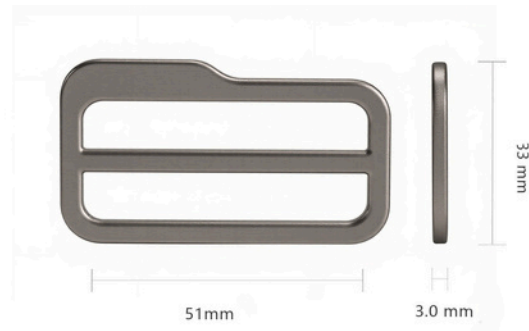

877
Barrel Plating, Gunmetal



2281
E-Coating, Black



1224
E-Coating, Black, Matt

SNAP HOOKS



38 mm



61.5mm

1078+117

Zamak 3/5

E-Coating, Black, Matt



A2216, Barrel
Plating, Nickel



186, Rack
Plating, Chrome

Sizes:

- 10mm (3/8")
- 13mm (1/2")
- 20mm (3/4")
- 25mm (1")
- 32mm (1¼")
- 38mm (1½")
- 50mm (2")



19.6 mm



47.4 mm

A1970

Zamak 3/5

Rack Plating, Gold



5028, E-Coating,
Black, Matt



A2580+A2595,
E-Coating, Black



12.8 mm



72.4 mm

A2599

Material: Zamak 3/5 Zinc Alloy
Surface Finish: Rack Plating, Nickel



27 mm



59.3 mm

A1853

Material: Zamak 3/5 Zinc Alloy
Surface Finish: E-Coating, Black

SNAP HOOKS



A1819

Material: Zamak 3/5 Zinc Alloy
Surface Finish; Baked Enamel, Beige

- Sizes:**
- 10mm (3/8")
 - 13mm (1/2")
 - 20mm (3/4")
 - 25mm (1")
 - 32mm (1¼")
 - 38mm (1½")
 - 50mm (2")



963, E-Coating, Black



A2754, Rack Plating, Gunmetal



A1909, Rack Plating, Gold



85+110

Material: Zamak 3/5 Zinc Alloy
Surface Finish: Barrel Plating, Nickel, Matt



A2031

Barrel Plating, Gunmetal



A2482+A483

Barrel Plating,
Gunmetal



2156, E-Coating, Black

SNAP HOOKS



58 mm

345

Material: Zamak 3/5 Zinc Alloy
Surface Finish: Barrel Plating, Nickel

- Sizes:**
- 10mm (3/8")
 - 13mm (1/2")
 - 20mm (3/4")
 - 25mm (1")
 - 32mm (1¼")
 - 38mm (1½")
 - 50mm (2")



38mm

50mm

935

Rack Plating, Gunmetal



37 mm

67.5 mm

A2662

E-Coating, Black, Matt



25.4 mm

47.5 mm

A2312

E-Coating, Black, Matt



40 mm

46 mm

A2656+A2657

E-Coating, Black, Matt



9.8 mm

33 mm

A2645+A2650

Barrel Plating, Nickel



10mm

40mm

262

Barrel Plating, Light Gold

ZIPPER PULLERS

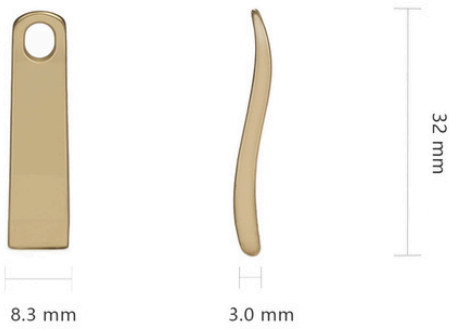

560
Barrel Plating, Gold



1593
Rack Plating, Gunmetal



A1905
Barrel Plating + TPU, Gunmetal



2529
Rack Plating, Chrome

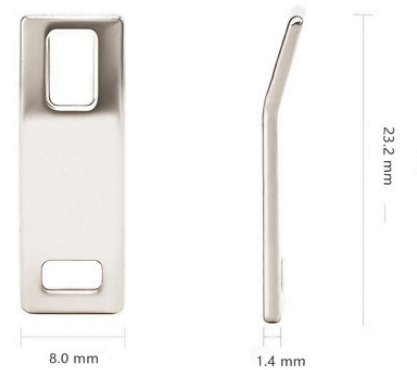

A2088
Rack Plating, Nickel



855
Baked Enamel, Red



2290
Rack Plating, Gunmetal



2660
Rack Plating, Nickel

PLATES & TAGS

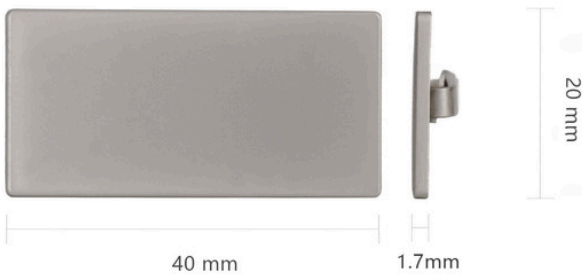

5116
Rack Plating, Nickel, Matt

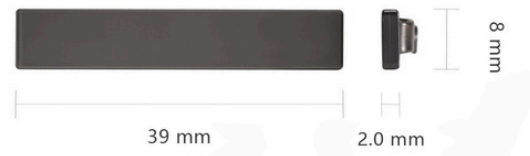

2338
Rack Plating, Gunmetal, Matt

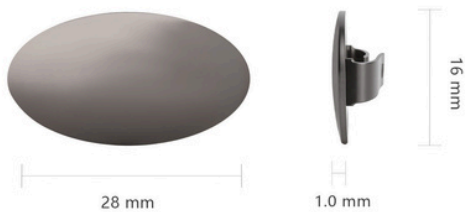

1835
Rack Plating, Gunmetal, Matt

MISCELLANEOUS



A2009, Rack
Plating, Nickel



2371, E-Coating,
Glossy Black



A2060, E-Coating,
Black, Matt

STRAPS & ACCESSORIES



SURFACE FINISHES

Electroplating(galvanic treatments): An electrochemical process that uses direct current to deposit a thin layer of metal onto a conductive substrate, enhancing properties like corrosion resistance, wear resistance, electrical conductivity, and aesthetics.

Colors: Nickel; Chrome; Silver; Gold; Copper; Gunmetal; Tin; Nickel-Free;



Texture: Satin; Brushed; Antique;



Gloss Level: Glossy(Default); Matt;

Physical Vapor Deposition (PVD): A versatile vacuum coating process used to produce thin films by transitioning solid material into a vapor phase and condensing it onto a substrate.

Colors: Nickel ; Black Nickel; Chrome; Silver; Gold; Copper; Gunmetal; Tin; Nickel-Free;

Texture: Satin; Brushed; Antique;

Gloss Level: Glossy(Default); Matt;

Baking paint (baked enamel): A surface treatment process that solidifies paint through high-temperature baking. The core steps include spraying paint and baking in a high-temperature oven (usually 60 ° C~200 ° C), allowing the paint film to quickly harden and form a durable and smooth surface.

Colors: Black; White; Beige; etc.;

Gloss Level: Glossy(Default); Matt;

E-Coating (electrophoretic painting): A high-tech process in which metal components are covered in a protective finish by submersing them in a chemical bath and applying an electrical current.

Colors: Black; ●

Gloss Level: Glossy(Default); Matt;

Jin Global
Jinghui Hardware Co., Ltd.



Contact

Lelystad, Netherlands | Guangzhou, China

Tel. +8618664546138

Website www.jinglobal.co

E-mail jinglobal.contact@gmail.com

